

EVOLUTION



Table of Contents

Introduction	3
Indication for Use	3
Installation and Preventative Maintenance	3
Safety	4
Safety Symbols	4
Safety Precautions	5
Specifications	5
Hot/Cold Water Mixing Valve.....	6
How It Works	6
Installation.....	7
Water Supply Installation Example	8
Tempered (Mixed) Water Parts List	8
Cold Water Parts List	8
Programming and Calibration.....	12
Reports	16
Operating Evolution	17
Solution Blending Devices and Alarms	18
Preventative Maintenance Checks	19
Troubleshooting	20
Replacement Parts.....	21
System Exploded View.....	22
System Wiring	24
Decontamination Procedures	25
Warranty	28

©2016 Knight LLC. All rights reserved. Evolution is a trademark of Knight LLC. The trademarks and names of other companies and products are the property of their respective owners.

Introduction

The Evolution™ is a cleaning solution blending and batching system that relies on Knight's unique fluid metering technologies to produce precise cleaning solutions. This patent pending revolutionary flow meter based system includes an advanced microcontroller with special software algorithms for blending of factory quality, ready-to-use solutions for medical device presoaking, manual instrument cleaning and hard surface cleaners and disinfectants. Evolution records each solution blending event to help managers track solution turn over, cleaning/soaking temperatures and use costs.

Indication for Use

Recommended applications include:

- Automatic blending/filling of cleaning solutions into manual instrument cleaning sinks prior to automatic washing
- Automatic blending/filling of cleaning solutions into instrument trays and tubs for soaking of medical devices
- Automatic blending/filling of cleaning solutions into mop buckets or tubs for cleaning of operating room equipment, floors and sterile processing department sinks and work surfaces

Installation and Preventative Maintenance

- All service and maintenance should be carried out by trained and authorized personnel
- Only original Knight replacement parts should be used for repair and maintenance
- The unit shall be used in accordance with the procedures and applications contained herein



This operating manual contains all information required for installation, start up and preventive maintenance.







Note: this operating manual is a required component for the system and should be made available at all times to the operator and maintenance staff.

General Safety

- Wear protective clothing and eye protection whenever operating this system.
- Wear protective clothing and eye wear when handling chemicals. Observe safe handling instructions (SDS) provided on chemical container or as supplied by chemical manufacturer.
- To avoid physical injury, always disconnect main power when servicing the unit.
- When installing any equipment, ensure that all national and local safety, electrical and plumbing codes are met.
 - System is for indoor use only
 - Do not submerge or place in direct path of spray/moisture
 - System operates with safe 24 Volt DC power

Safety Symbols

Listed below are explanations of the safety symbols that appear either on the unit, in the instruction manual, or both. Please familiarize yourself with the meaning of each symbol.

	"ON" (power)
○	"OFF" (power)
◻	Class II Equipment
	Operating Instructions
	Follow operating instructions
	Refer to instruction manual/ booklet
	General warning sign
	This device contains electrical and/or electronic equipment that must be recycled per EU Directive 2012/19/EU – Waste Electrical and Electronic Equipment (WEEE)
	Caution risk of electric shock or Attention Dangerous Voltage

Personal Protective Equipment (PPE)



gloves



garment





face shield



do not drink

Specifications

Case materials	#304 stainless steel
Case rating	IP-XO
Water solenoid valve	24 VDC
Power supply	Wall Mount Type, In: 100-240 VAC 1A 50-60 Hz Out: 24 Volts DC 1.67A 
Power supply (alternate)	Wall Mount Type, In: 100-240 VAC, 1.4-0.7A, 50-60 Hz Out: 24 Volts DC 2.5A 
Backflow Preventer	Pipe interrupter with atmospheric vent and moving element DB Type valve suitable for up to Fluid Category 4 Conforms to EN 1717 (KIWA Approvals)
Chemical check valve material	Polypropylene/EPDM
Solution discharge hose material	PVC
Faucet Spout	Chrome plated copper
Chemical suction tubing	PVC
Chemical suction tube weight material	Ceramic
USB drive recommendation	SanDisk® Cruzer Glide
Temperature sensor	RTD type, +/- 2%
Flow meter materials	PVDF (Water), PPS (Chemical)
Unit dimensions/weight	11" H x 9" W x 7.1" D/16 lbs 28 cm x 23 cm x 18 cm/7.25 kg
Electrical Safety	CAN/CSA-C22.2 No. 61010-1-04 UL Std. No. 61010-1 (2nd Edition) EN 61010-1:2010 
Level sensor materials	PVC, Polypropylene, ABS
Water connection to unit (North American standard)	½" NPT (14 MM BSP)
Environmental Rating	Standard
Designed for Use	Indoor Use Only
Installation Category	II
Pollution Degree	2
Operating Temperature Range	15°C to 35°C
Operating Humidity Range	10-75% Non-Condensing
Storage Temperature Range	1°C to 52°C
Storage Humidity Range	5-90% Non-Condensing

Hot/Cold Water Mixing Valve

To provide tempered water to the sink or receptacle a water tempering valve can be used. Follow all local plumbing and safety codes when installing these devices. See page 8 for recommended configuration and installation.

How it works

Select from one of four batch volumes and solution concentrations, then press the START button to automatically fill instruments sinks or soaking tubs with the precise ratio of concentrated chemical and water. Optional soak time function counts down the time for the medical devices to be submerged in the cleaning solution. An audible tone alerts the technician when soak time has been reached. Usage data can be downloaded from the system via USB drive or viewed on the display.



Volume Selection Screen



Flexible Hose Model



Rigid Spout Model

The Flexible hose model should be used where filling of sinks or tubs are not directly beneath where the system will be mounted. The 8-ft (2.4 M) flexible hose can be placed inside the sink or tub and held in place with a hose adaptor or vinyl suction cup.

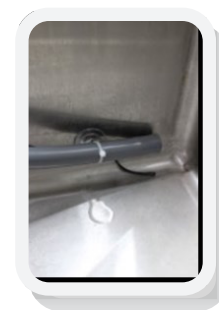

Rigid spout models are generally used where a fixed location for filling tubs is desired. The spout stays above the work area and swivels up to 180 degrees.



Installation

1. Identify a suitable location on the wall above the sink or where filling of the sink or tubs is to take place. Make sure a power source is within 6 feet (1.8M) or you will need to extend the power supply.
2. Position unit on the wall and mark mounting hole locations. Install provided anchors and screws and secure unit on the wall.
3. Secure bottom of unit using lower mounting hole below peristaltic pump.

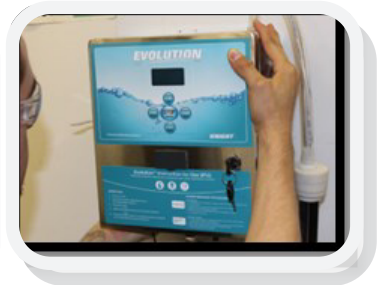
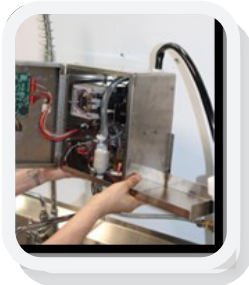
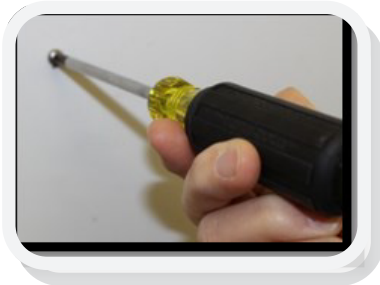

4. Installing the water supply

Important Note:

- Identify the location of the water source to be used. Most common is to connect into the hot/cold supply lines from under the sink.
- Since the water faucet is essential to the operation of the sink you will need to “T” into the water supply using the appropriate fittings, hose and connectors. The example below includes a water tempering valve for hot/cold water mix. Actual fitting sizes, braided hose lengths, standard/metric pipe connections should be planned in advance based on the configuration of the plumbing system in each location.

Typical Water Supply Connection for Tempered or Cold Water Installation

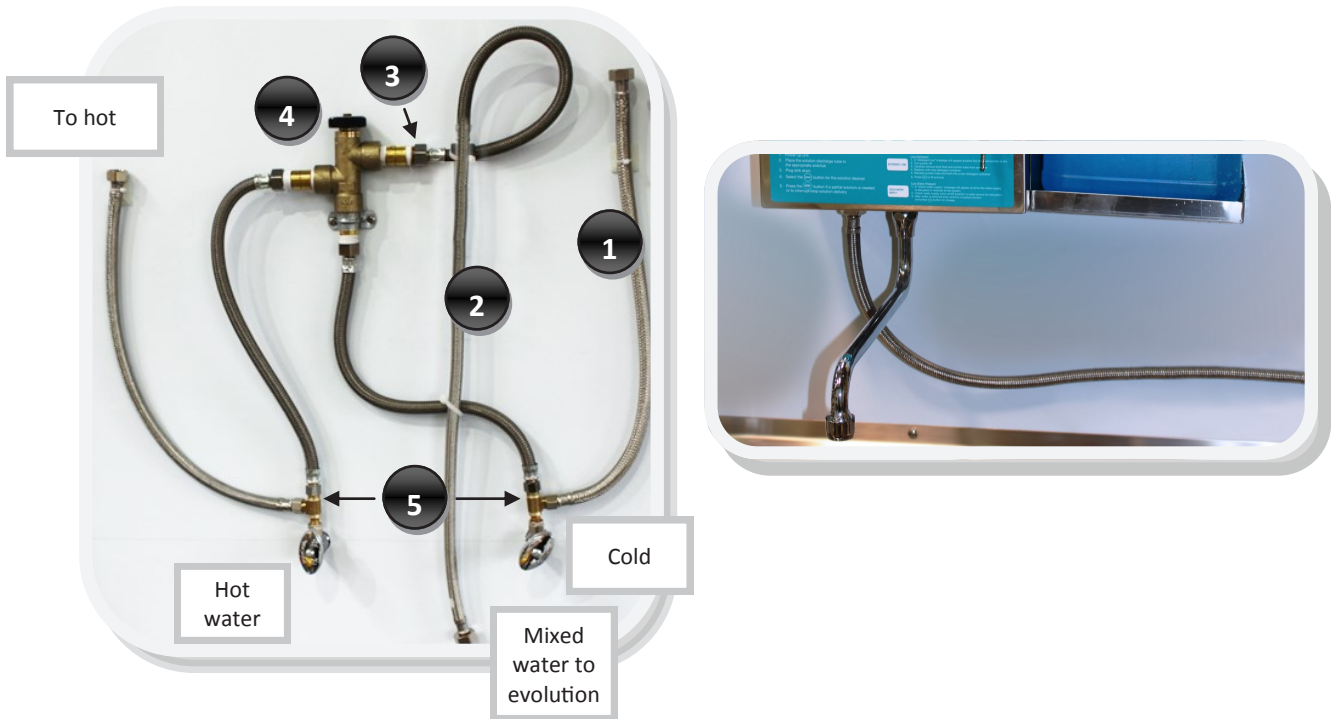

Tempered (Mixed) Water Parts (Not Included)

Item #	Description	Qty
1	Braided appliance hose, 1/2" FPT x 3/8" compression	4
2	Braided appliance hose, 1/2" FPT x 1/2" compression	2
3	Pipe nipple, 1/2" x 1"	4
4	Tempering Valve, 1/2" Watts LF 70	1
5	Adaptor, 3/8" x 3/8" x 3/8" compression	2

Cold Water Parts (Not Included)

Item #	Description	Qty
1	Braided appliance hose, 1/2" FPT x 3/8" compression	2
2	Braided appliance hose, 1/2" FPT x 1/2" compression	1
3	Pipe nipple, 1/2" x 1"	1
4	Tempering Valve, 1/2" Watts LF 70	n/a

5. Connect water source to the bottom of the unit. Use a braided water hose to connect to the ½" NPT brass nipple on the bottom of the unit.

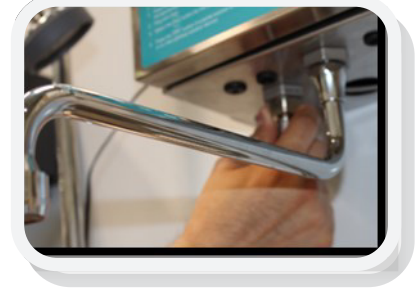
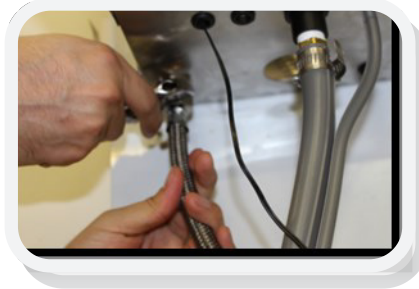

6. Plug the power cord into a nearby wall outlet.

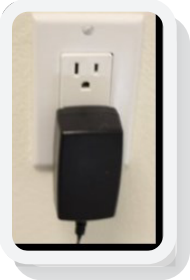

7. Plug in low voltage side of the power supply to female power port on side of the case.

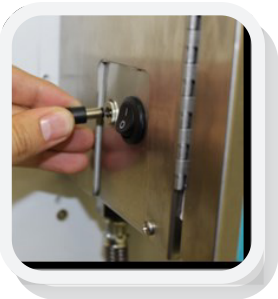

8. Attach solution hose bracket (if equipped) to left side of the case with two screws provided.



9. Attach the five liter container shelf (if equipped) to right side of case using screws provided.



10. If unit is equipped with spout attach it to the male connector on the bottom of the case and secure with a wrench. Avoid over tightening.

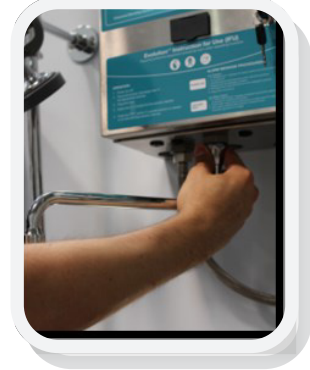

11. Install chemical level sensor.

a. Five Liter

- i. Remove plug from top of the case as shown

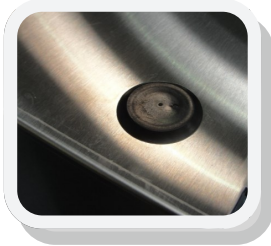

- ii. Insert level sensor cable and suction tube through barb fitting and push through opening in the top of the case. Secure barb fitting with lock nut provided and push outer tube over barb as shown

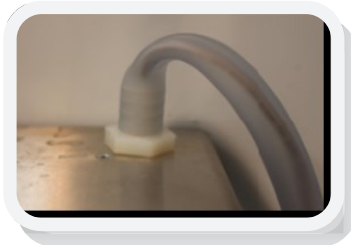
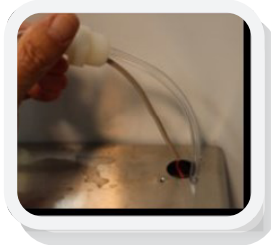

- iii. Connect level sensor wire harness (red/black wires) to wires marked level sensor (black and purple) black to black, red to purple

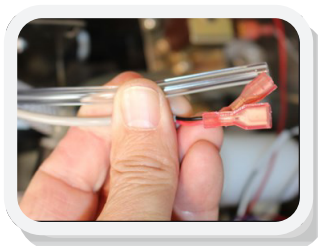

b. 10 Liter Level Sensor Installation

- i. Insert cable leads through bottom of case as shown and connect level sensor wire harness (red/black wires) to wires marked level sensor (black and purple) black to black, red to purple.

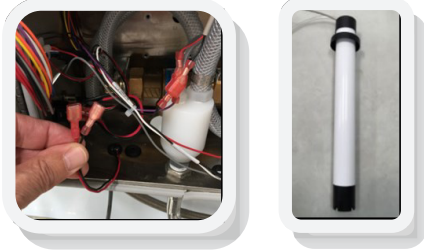

12. Drop level sensor with suction tube into the chemical container and secure in place.

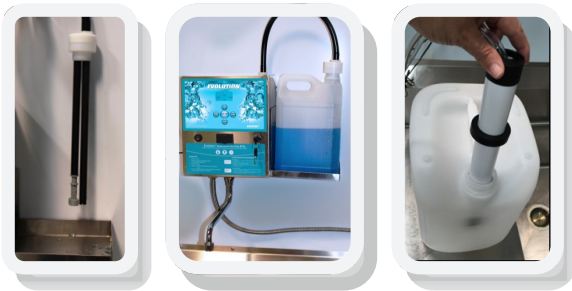

13. Insert the cleaning solution suction tube through grommet in bottom of the case and connect to the suction side of the peristaltic pump. Secure with wire tie.

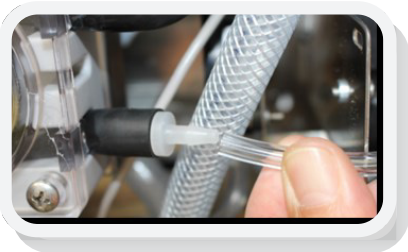

14. Attach the temperature sensor to the solution hose and secure in place with wire ties provided. If the temperature sensor is to be used be sure it is positioned at the end of the hose or bottom of the sink where the solution will come into contact with it. Attach vinyl suction cups to the hose using wire ties and position the hose in the tub as needed. If the rigid hose bracket is to be used the temperature sensor can be installed by itself using the suction cup at the bottom of the sink.

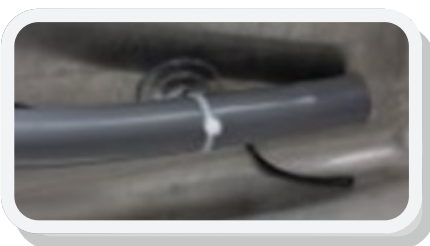

Hose and temperature sensor secured to suction cup.



Programming and Calibration

1. Position a tub or graduated cylinder under the solution discharge fitting or spout located on the bottom of the unit.
2. Hold the Stop/Enter key down until the display color changes to blue. Press the enter key to accept 0000 usercode. Press enter again to bypass change of user code at this point.
3. Press the Up key to start priming of the chemical. Press the Up key again to stop prime.
4. Turn on water source
5. Press Up key to prime water through the system. Press Up again to stop.
6. We won't download or view reports at this time. Press the Enter key to skip this function for now.
7. Press the Enter key again to skip the date range.
8. To access the basic features in the programming mode, you will need a user pass code. To enter a user pass code, use the SCROLL button to scroll between digits and the UP and DOWN buttons to cycle between 0-9. By default, the pass code is set to 0000.

Press ENTER to advance to the next screen.
9. To change the existing user pass code, use the SCROLL button to scroll between the digits and use the UP and DOWN buttons to cycle between 0-9.

Press ENTER to advance to the next screen.
10. To set the time and date, press the SCROLL button to scroll between hour/minutes/seconds/meridiem/month/date/year, and the UP and DOWN buttons to cycle through the digits.

Note: When entering the time, you must enter it in a 12 hour time format.
11. To change the language, use the SCROLL button to toggle between languages.

Press ENTER to advance to the next screen.

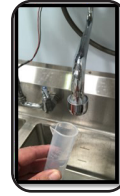

PRESS SCROLL TO ENTER USERCODE
0000

PRESS SCROLL TO CHANGE USERCODE



PRESS UP TO START WATER PRIMING

SELECT DATA DOWNLOAD OR ON-SCREEN REPORTS DATA DOWNLOAD TO USB

ENTER DATE RANGE TO GET REPORTS FROM 27-03-15 TO 27-03-15

PRESS SCROLL TO ENTER MAINCODE
0000

PRESS SCROLL TO CHANGE MAINCODE

PRESS SCROLL TO CHANGE DATE/TIME
TIME 10:41:25AM
DATE 27-03-15

PRESS SCROLL TO SELECT WHICH LANGUAGE TO USE
ENGLISH

PRESS SCROLL TO SELECT WHICH LANGUAGE TO USE
FRANCAIS

Programming and Calibration (cont.)

12. Evolution allows you to select the unit of measure for calculating the solution blending rate. Select the unit of measurement (UOM) as stated in the instructions for use on the chemical container label. The UOM used for programming the blending rate will be used on the run screen display. Use the scroll key to select and press enter to proceed to the next menu

PRESS SCROLL TO
SELECT WHICH CON-
CENTRATION TO USE
UNITS USED: %

PRESS SCROLL TO
SELECT WHICH CON-
CENTRATION TO USE
UNITS USED: OZ/
GALLON

PRESS SCROLL TO
SELECT WHICH CON-
CENTRATION TO USE
UNITS USED: ML/
LITER

13. Use the scroll and Up/Down keys to enter the formula batch volume and blending rate.

A volume of 0 will hide the formula from the main screen. A concentration of 0 will dispense only water and no chemical.

PRESS SCROLL TO ENTER
FORMULA VOLUMES AND
CONCENTRATIONS:

FORM 1: 003L	2.50%
FORM 2: 015L	0.50%
FORM 3: 020L	1.00%
FORM 4: 040L	5.00%

14. When one or more of the formula settings is not used the soak timer feature will appear on the run screen. Use the scroll and Up/Down keys to enter soak time. An audible tone will sound once the soak timer has counted down.

PRESS SCROLL TO
ENTER SOAK TIME:

(MIN:SEC)

15. For blending of disinfectant solutions Evolution provides added assurance that every batch produced results in a ready to use concentration that meets or exceeds the manufacturers' recommended blending rate. Following final calibration of the system dispense any of the programmed formulas and measure the concentration. If the concentration is under (or over) the target use the Calibration adjustment by selecting scroll and Up/Down keys to program the adjustment. Press enter when done, exit the programming menus and dispense another test batch to check the results.

PRESS SCROLL UP/
DOWN TO ENTER
CALIBRATION
ADJUSTMENT
OVERFEED = 00%

PRESS SCROLL UP/
DOWN TO ENTER
CALIBRATION
ADJUSTMENT
OVERFEED = 02%

PRESS SCROLL UP/
DOWN TO ENTER
CALIBRATION
ADJUSTMENT
UNDERFEED = 01%

16. To calibrate cleaning solution volume, use a 100 ml graduated cylinder. Be sure the pump is fully primed before you start. Hold the graduated cylinder directly under the solution discharge fitting or spout. Press the Up key to start dosing cleaning solution. The pump will stop on its own.

PRESS UP TO START
PUMP
CALIBRATION FOR 100
ML



Programming and Calibration

17. Enter the amount of cleaning solution dispensed into the graduated cylinder and press enter. Repeat this procedure until you capture 100 mL +/- 2 mL. If the volume dispensed is 100 mL +/- 2 mL press ENTER to proceed to the next step.

ENTER CAPTURED
VOLUME IN ML

VOLUME = 000ML

18. To calibrate water use a 1000 ml graduated cylinder. Be sure the water line is fully primed before you start. Press the Up key to start dispensing water. The water will stop on its own.

PRESS UP TO START
WATER CALIBRATION
FOR 1000 ML

Enter the volume captured and press ENTER. Repeat the procedure until you capture 1000 mL (1 liter) +/- 10 mL.



19. Reinstall the solution hose after final calibration is complete.



20. If temperature of the cleaning solution is important for cleaning efficacy the temperature range can be monitored by setting a minimum and maximum temperature. The system will alarm and record a low temperature error anytime solutions fail to reach or exceed min/max temperatures. Use the scroll and Up/Down buttons to set. Press enter to save values and proceed to next menu.

PRESS SCROLL TO
ENTER TEMP RANGE
MIN TEMP

020C

PRESS SCROLL TO
ENTER TEMP RANGE
MAX TEMP

070C

21. If the temperature reading appears to be incorrect use the Up/Down keys to calibrate the temperature sensor. Use a calibrated thermocouple or analog temperature sensor to verify the temperature then adjust the temperature setting accordingly.

PRESS UP/DOWN TO
ENTER CALIBRATION
TEMPERATURE
TEMP (C)

22. Temperature monitoring is used when it takes an extended period of time to get hot water from the boiler to the sink. To avoid filling the sink with cold water turn this feature on (scroll key). The temperature sensor in the sink will sense when the minimum water temperature is reached and beep 3 times. The technician will then close the sink drain and press the START button to fill the sink with the correct temperature solution.

PRESS SCROLL TO
TURN TEMP MONITOR-
ING ON OR OFF
TEMP MONITORING OFF

PRESS START TO RUN
WATER UNTIL TEMP. IS
IN RANGE

TEMP (F)

Programming and Calibration (cont.)

23. Evolution can record up to 20,000 records. Once 20,000 records have been saved the system will overwrite the oldest records with the new. Use this menu to clear these records.

PRESS SCROLL AND
DOWN TO CLEAR
USAGE DATA
MEMORY

ARE YOU SURE?

DONE

24. To view reports or save to a USB stick for viewing/printing on a PC use this menu. Use the scroll key to select Data Download to USB or On Screen Report. Press Enter to proceed.

SELECT DATA DOWN-
LOAD OR ON-SCREEN
REPORT

SELECT DATA DOWN-
LOAD OR ON-SCREEN
REPORT

ON-SCREEN REPORT

DATA DOWNLOAD TO USB

25. Press the scroll button until the cursor is on the To or From lines and use the up/Down keys to select the date range for your report. Summary Reports provide high level information about blending activity, out of chemical alarms and chemical/cleaning solution usage.

ENTER DATA RANGE
TO GET REPORTS

FROM 03-27-15
TO 03-27-15

SUMMARY REPORT

RECORD COUNT: 0000
CHEMICAL USE: 00.0 G

26. For printed reports that can be opened in any text editor program (Excel, Notepad, Word etc.) select your date range, once it is correct, insert the USB stick and press Enter. Remove the USB stick when the display says "Done".

ENTER DATA RANGE
TO GET REPORTS

FROM 03-27-15
TO 03-27-15

COPYING DATA....

DONE

Report Viewing/Printing



1. Insert USB drive into your PC.
2. Double-click on the file name (*.txt)
3. Copy report content into Excel, Word, or save as .txt format for future reference.

Metric Mode Report with formula mls/Liter blending rate

```

Dispenser S/N: 0000000

Report Date: 05/10/15
From Date: 05/10/15
To Date: 05/10/15

Date      Time      Formula(ml) water in L  Chem. in ml  Temperature  Errors
05/10/15  11:43:56AM  10.0        0000.9       0010.0       0020
05/10/15  11:44:09AM  20.0        0001.9       0040.0       0020
05/10/15  11:44:30AM  50.0        0004.7       0250.0       0020

Chem. Usage: 000.3 Liter
Water Usage: 007.5 Liter
    
```

Metric Mode Report with formula % blending rate

```

Dispenser S/N: 0000000

Report Date: 05/10/15
From Date: 05/10/15
To Date: 05/10/15

Date      Time      Formula(%) water in L  Chem. in ml  Temperature  Errors
05/10/15  10:23:23AM  1.00       0000.9       0010.0       0020
05/10/15  10:23:37AM  2.00       0001.9       0040.0       0020
05/10/15  10:30:55AM  5.00       0004.7       0250.0       0020

Chem. Usage: 000.3 Liter
Water Usage: 007.5 Liter
    
```

Standard (U.S.) mode with % blend rate

```

Dispenser S/N: 0000000

Report Date: 05/10/15
From Date: 05/10/15
To Date: 05/10/15

Date      Time      Formula(%) water in G  Chem. in oz  Temperature  Errors
05/10/15  10:36:50AM  1.00       0000.9       0001.2       0068       Out of Temprange
05/10/15  10:37:34AM  2.00       0001.9       0005.1       0068       Out of Temprange
05/10/15  10:38:48AM  5.00       0004.7       0032.0       0068       Out of Temprange

Chem. Usage: 000.2 Gallon
Water Usage: 007.5 Gallon
    
```

Standard (U.S.) mode with oz/gallon blend rate

```

Dispenser S/N: 0000000

Report Date: 05/10/15
From Date: 05/10/15
To Date: 05/10/15

Date      Time      Formula(oz) water in G  Chem. in oz  Temperature  Errors
05/10/15  10:48:03AM  1.00       0000.9       0001.0       0069       Out of Temprange
05/10/15  10:48:56AM  2.00       0001.9       0004.0       0068       Out of Temprange
05/10/15  10:50:12AM  5.00       0004.7       0025.0       0068       Out of Temprange

Chem. Usage: 000.2 Gallon
Water Usage: 007.5 Gallon
    
```

Operating Evolution

User Interface Operator Key Function – formulas are arranged at the 9, 12, 3 and 6 o'clock positions just like the start buttons. Select the start button that coincides with the formula to be dispensed and press the button. Unless temperature monitoring function is turned on the unit will start to dispense the cleaning solution.



1. **Place the solution hose (or faucet) in/over the sink/tub to be filled.** Be sure the hose is placed at the bottom to avoid excess aeration of the cleaning solution which can cause excessive foam.
2. **Temp Monitoring Mode On**

If the temperature sensor reads below the minimum temperature setting the display will show the message to run water.

The system will turn on the water valve and begin measuring the incoming water temperature. Once the minimum temperature is reached the system will beep three times indicating its time to close the drain. Press the appropriate Start button to fill at the correct temperature.

PRESS START TO
RUN WATER UNTIL
TEMP IS IN RANGE

TEMP (F) 071

3. **Temp Monitoring Mode Off**

Close the sink drain and press the appropriate formula start button for the volume and concentration desired. Go about some other task while Evolution completes delivery of the formula volume.

Note: If for any reason you need to interrupt a dispensed volume press the Stop button. All chemical volumes are recorded anytime you hear the audible “beep” that occurs at the end of a completed delivery or on an interrupted dispense after pressing Stop.

4. **Soak Timer**

Press the soak key to start a soak time countdown. At the end of the soak you will hear three beeps

5. **Replacing the Cleaning Solution Supply**

When the low detergent alarm sounds, remove the low level sensor from the cleaning solution container and replace with a fresh container. Once you drop the sensor into the container the alarm message will reset to the run screen. Drain the contents of any incomplete formula volume and start over to assure the proper concentration and volume is used.

Solution Blending Devices and Alarms

Water flow detection

The large flow meter connected to the water solenoid valve senses water flow and sends back signals to the main controller that water is flowing at the calibrated rate of flow. Anytime water flow drops below the calibration setting a flow alarm message will occur and the system will stop production of the current formula.

CHECK WATER
SUPPLY

Low level sensor

Chemical levels in the supply container are monitored by a float type level sensor. The level sensor should be positioned at the bottom of the chemical container along with the chemical suction tube. When the level float sinks to the bottom of its travel an alarm will sound, low detergent error recorded and display message "detergent low" message shown until the container is replaced.

DETERGENT LOW!

Temperature sensor precision/type

The RTD type temperature sensor will monitor water temperature to the specified range programmed into the system. With the temperature monitoring feature on an error will be recorded and alarm displayed if the system fails to reach the minimum temperature

PRESS START TO
RUN WATER UNTIL
TEMP IS IN RANGE.
TEMP (C) 022

PRESS START TO
RUN WATER UNTIL
TEMP IS IN RANGE.
TEMP (C) 022

Preventative Maintenance Checks

Component	Maintenance Requirement	PM Frequency
Water flow meter	Inspect cover o-ring. Replace as needed	12 months
Detergent flow meter	Inspect cover o-ring. Replace as needed	12 months
Peristaltic pump tube	Replace pump tube	6 months
Solution mixer assy	If internal check valves do not seal replace entire assembly	6 months
Suction filter/foot valve	Inspect condition of screen and check valve. Replace as needed	12 months
Flexible hose	Inspect for cracks, leaks or abrasions. Replace as needed	12 months
Temp sensor	Replace if showing signs of wear or inability to sense correct temperature. Recalibrate if replaced.	12 months
Backflow Preventer	Check Flex Gap rubber sleeve for wear/leaks	12 months
Various plastic fittings	Inspect for leaks or wear. Replace as needed.	12 months
User interface	Inspect for damaged keys or wear of the label material. Replace as needed	6 months

Troubleshooting

Issue	Probable Cause
Unit will not power up	<ul style="list-style-type: none"> • Power switch damaged • Loose wire on switch terminals • Check circuit breaker
Formula volume not accurate	<ul style="list-style-type: none"> • Recalibrate water • Recalibrate detergent • Check for low water pressure
Concentration not accurate	<ul style="list-style-type: none"> • Recalibrate detergent • Check/ replace solution adaptor check valves • Detergent flow meter gears stuck • Detergent flow meter sensor damaged
Detergent alarm stays on	<ul style="list-style-type: none"> • Bad level sensor float • Bad level sensor reed switch • Loose wire on level sensor connection at pc board
Water alarm will not clear	<ul style="list-style-type: none"> • Water pressure too low • Water flow meter gears stuck • Water flow meter sensor damaged
Cannot retrieve reports	<ul style="list-style-type: none"> • No saved data • Invalid date range • USB drive damaged or incompatible
Cannot view report summary	<ul style="list-style-type: none"> • No saved data • Invalid date range
Report showing incomplete volumes and frequent cycle interruptions	<ul style="list-style-type: none"> • Staff topping up sink/tubs • Staff needs training
Report showing frequent temperature alarms	<ul style="list-style-type: none"> • Temp sensor not place at sink bottom • Boiler not able to keep up • Damaged temperature sensor
Too much foam in sink	<ul style="list-style-type: none"> • Place solution hose not under water • Fixed pressure regulator damaged • Detergent Concentration too high
Formulas will not activate	<ul style="list-style-type: none"> • Faulty switch on circuit board • Circuit board loose • Program settings lost

Replacement Parts

Item	Part #
Flow meter, PVDF, Water	0600476
Flow meter, PPS, Detergent	6446000
Peristaltic pump tube, T-50E	7018050
Flexible hose. 8 feet.	7026924
Solution mixer assy	6446105
Spout, chrome	1900119
Umbrella foot valve	2201225-EP
Microcontroller, Evolution	7140845
Pressure regulator, fixed 50 PSI	7407116
Flex gap backflow preventer housing	6385001
Flex Gap backflow preventer stem	6385003
Flex Gap backflow preventer sleeve, EPDM	7001052
Fitting, Acetal, Elbow for backflow preventer, 3/8" barb	6592001
Check valve, 5/16", detergent	7901252
Check valve, 1/2" O.D , water	6446102
Temperature sensor	1600708
Peristaltic pump face plate	7502312
Water valve assy, 1/4", 24 VDC	7121062
Power supply, 40W/24 VDC	2000519
Label, Main w/ window	1201668
Label, IFU	1201669
Power switch, rocker	1900954
Motor, 200 RPM, 24 VDC	7010261
Water flowmeter cover o-ring	1500458
Detergent flowmeter cover o-ring	1500481

System Exploded View

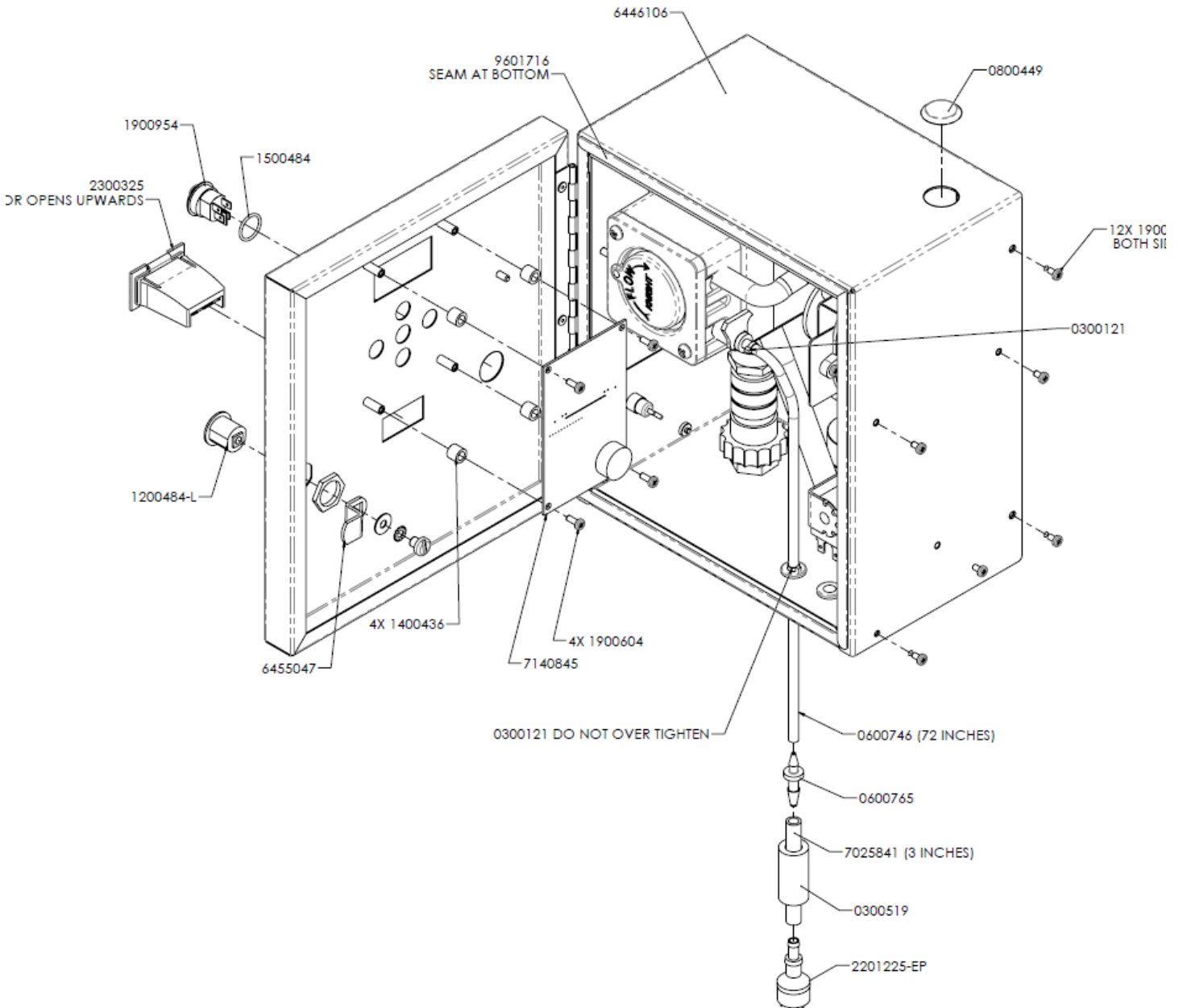

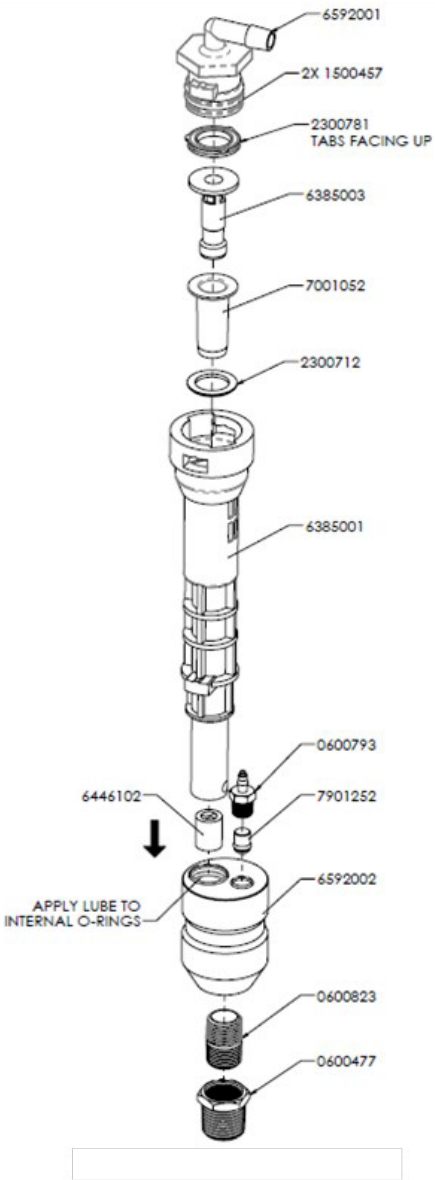
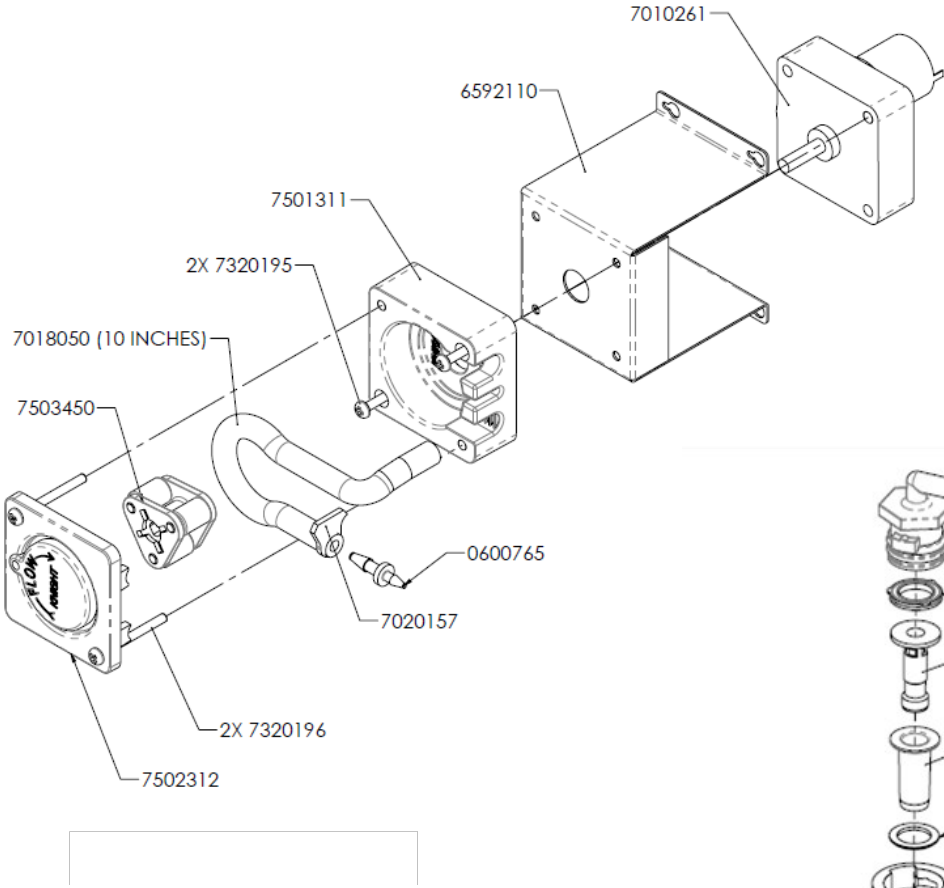

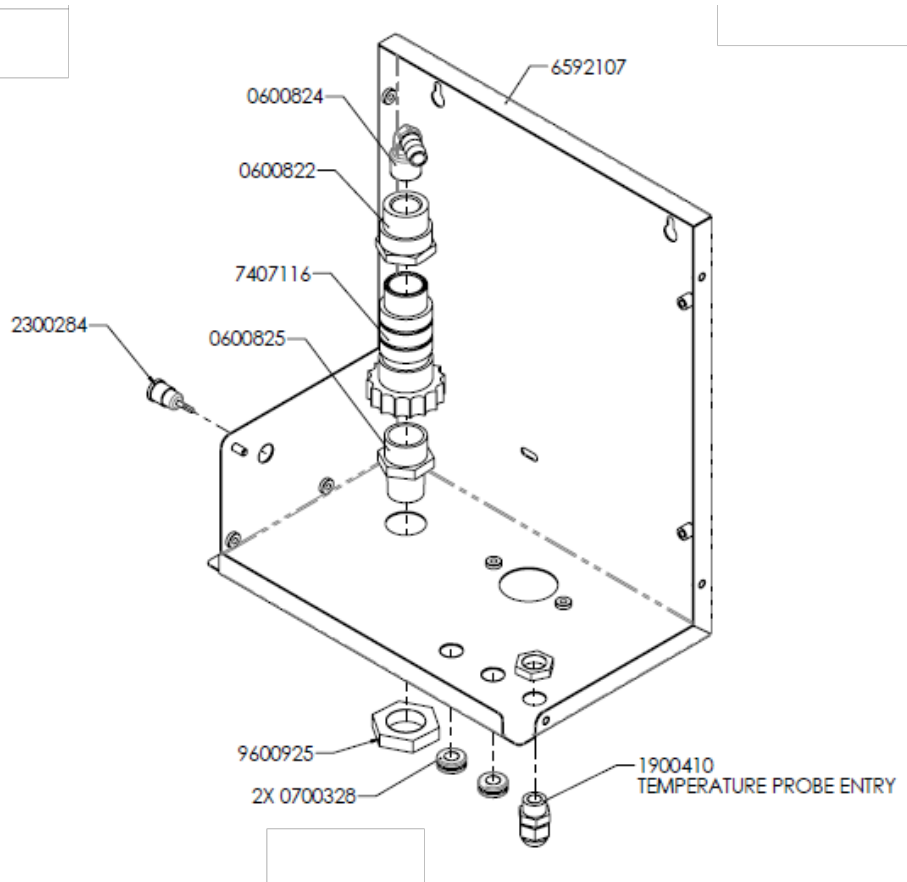
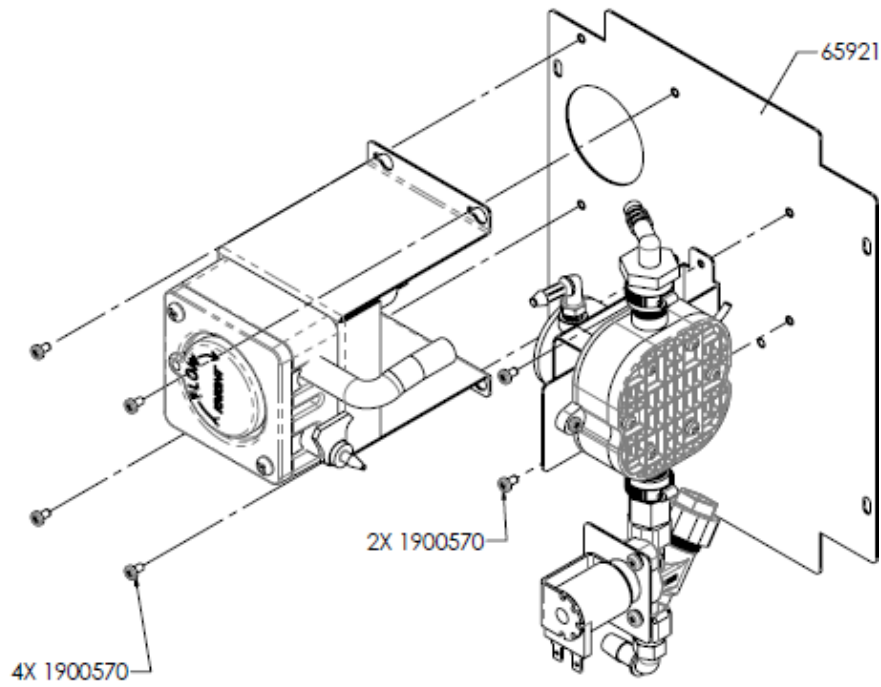

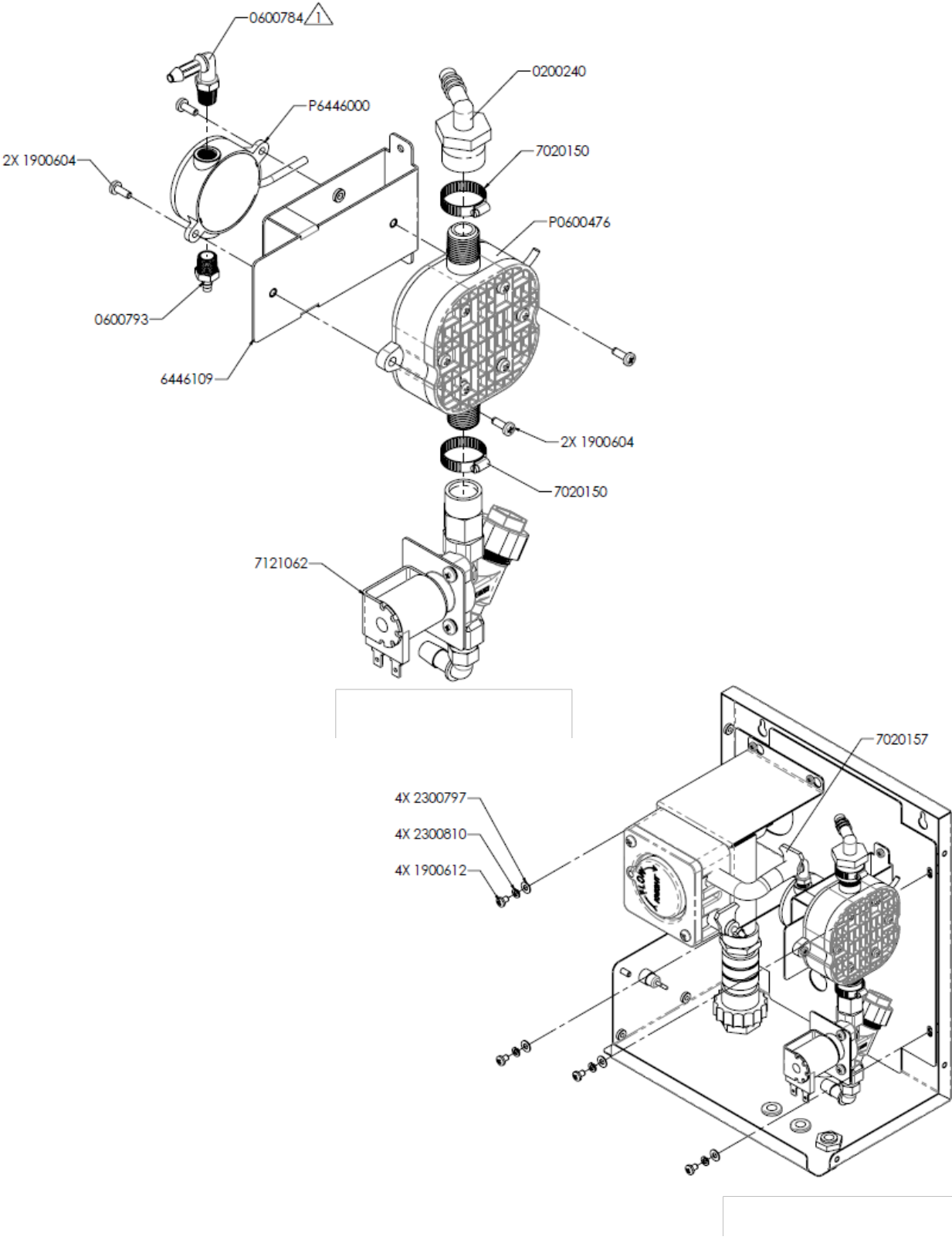

System Wiring

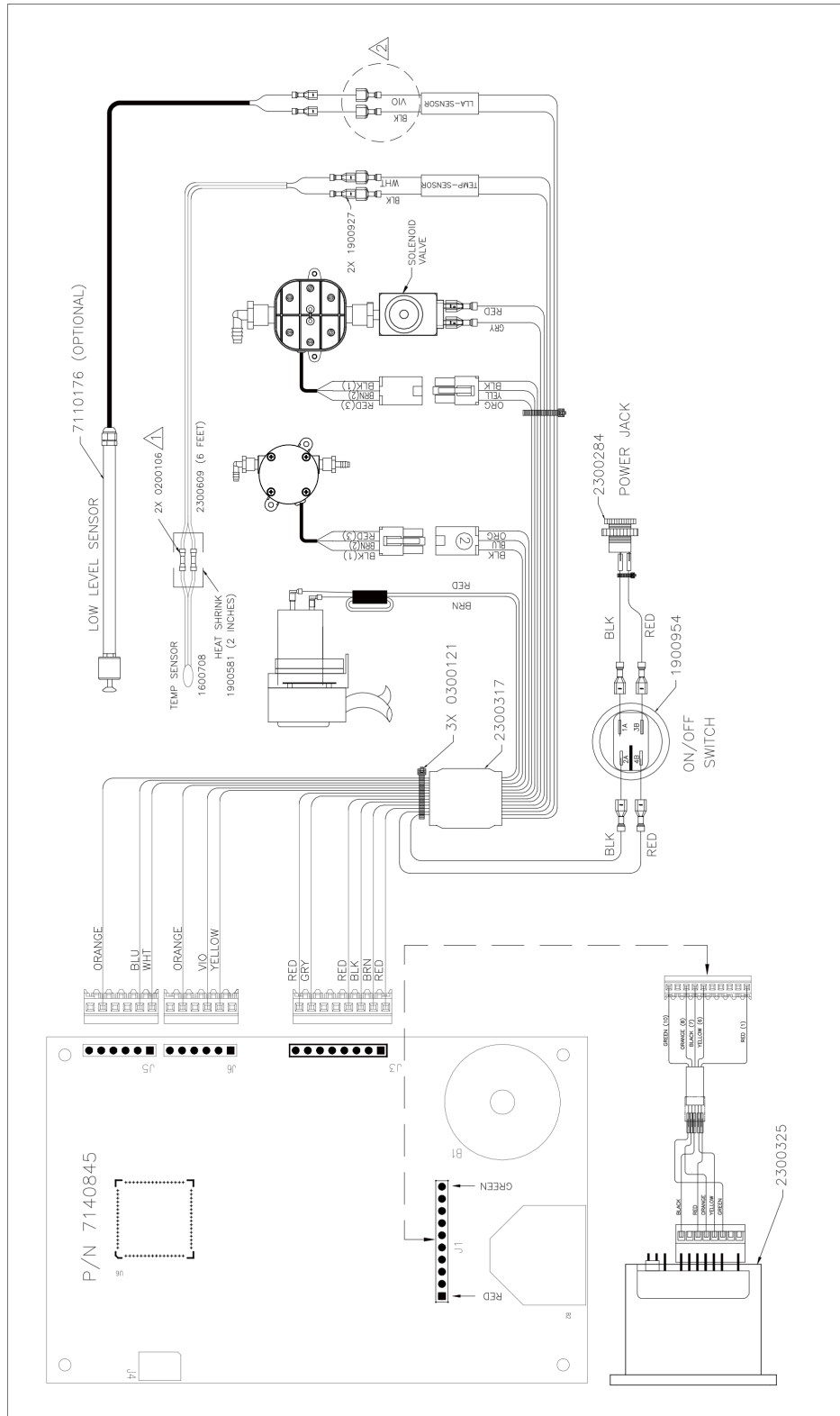

Decontamination Procedures

Use a clean damp cloth to remove contaminants from user interface panel and flexible solution hose.
Follow with a wipe down using a hard surface detergent/disinfectant.
Caution: avoid getting moisture in the USB port during cleaning

WARRANTY

For complete product terms and conditions scan the QR code below or enter the following URL into your browser:
<http://cfstech.info/t-and-c>

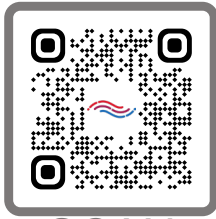

SCAN

DISCLAIMER

Knight LLC does not accept responsibility for the mishandling, misuse, or non-performance of the described items when used for purposes other than those specified in the instructions. For hazardous materials information consult the label, MSDS, or Knight LLC. Knight products are not for use in potentially explosive environments. Any use of our equipment in such an environment is at the risk of the user. Knight does not accept any liability in such circumstances.

FOOTNOTE

The information and specifications included in this publication were in effect at the time of approval for publishing. Knight LLC reserves the right to discontinue or change specifications or design at any time without notice and without incurring any obligation whatsoever.



KNIGHT LLC is part of the **CFS Technologies** family of brands.

www.knightequip.com | cfstech.com

8504 MacArthur Dr., North Little Rock, AR 72118 USA • 501-895-2820 | 800-999-2820

General: sales@cfstech.com | Tech. Assist.: techsupport@cfstech.com