

PMP SERIES

PERISTALTIC METERING SYSTEM

INTRODUCTION

The PMP Series peristaltic metering pump system is designed to dispense a variety of cleaning and sanitizing chemicals. Positive, accurate metering of liquids can be triggered manually or by a process control signal.

The PMP Series provides fixed speed output with the option of a programmable limit-timer. PMP is built with Knight's field proven, long-life peristaltic pumps. Moisture sensitive motor and controllers are enclosed in a corrosion resistant, watertight, powder coated case that stands up well for indoor and outdoor applications.

KEY FEATURES / BENEFITS

- Watertight, Secure Locking Enclosure
- Long-Life Peristaltic Pumps
- Water Resistant Case w/"D" Shaped Silicone Gasket
- Long Lasting Squeeze Tube
- Fixed Speed Pump
- Choice of three Flow Rates
- Pumps Up to 30 PSI
- Self Priming, Easy to Service

KTM-600 MODEL FEATURES & OPTION

- Auto-Start or Manual Activation
- Optional Remote Activator Button
- Microprocessor, Push Button Programming
- Pump Lockout Feature

APPLICATIONS

FOOD & BEVERAGE PROCESSING PLANTS: CIP/COP, Grease Traps, Sewage Treatment

DAIRY: Pipeline Cleaning/Sanitizing, Teat Dip Chemical, Wash Pen Chemical Injection

INDUSTRIAL: General Cleaning, Machinery Lubrication, Cooling Towers, Boilers

TRANSPORTATION: Car Wash Stations



PMP-800 Series



PMP-900 Series



**#7640616 Remote Activator
(optional for KTM-600 model)**

WARNING!

- ✓ Pump is designed to operate with factory-supplied fittings.
- ✓ Use “Worm Gear” clamps only for all liquid end connections.
- ✓ Minimum suction tube I.D. must be 3/8” for 800B Pumps.
- ✓ Minimum Suction tube i.D. must be 1/2” for 900 pumps.
- ✓ There can be no other restrictions on suction tube.
- ✓ Factory warranty is void if installation and operating procedures are not followed. See instruction manual.
- ✓ Call or email Knight for technical support or visit our website.

techsupport@cfstech.com

(800) 999-2820

www.knigthequip.com



CAUTION: Wear protective clothing and eyewear when dispensing chemicals or other materials. Observe safety handling instructions (MSDS) of chemical mfrs.



CAUTION: To avoid severe or fatal shock, always disconnect main power when servicing the unit.



CAUTION: When installing any equipment, ensure that all national and local safety, electrical, and plumbing codes are met.

RECOMMENDED OPERATING PARAMETERS

Pump Model	Duty Cycle	Maximum Pump Run Time	Maximum Lift (Suction)	Maximum Head Pressure
PMP-800 Series	50%	5 Minutes	10 Feet (3 Meters)	30 PSI (2 Bar)
PMP-900 Series	10%	5 Minutes	10 Feet (3 Meters)	30 PSI (2 Bar)

NOTES:

The duty cycles and maximum pump run time specified above can be exceeded, however in doing so the life of the squeeze tube, roller block and motor will be reduced.

Fixed speed (AC drive) pumps have a thermal cut-out that will stop the pump if it overheats. The duty cycle of the pump and ambient temperature contribute greatly to the overall run time capability, regardless of the maximum allowable time that can be set on the circuit board (if so equipped). If the thermal cut-out activates to stop the pump, the pump must cool down before it can resume normal operation.

SPECIFICATIONS

- Enclosure: Powder coated stainless steel.
- Pump Drive: Shaded pole AC.
- Squeeze Tube: Material available for most chemical applications.
- Control: Limiting timer available.
- Power Supply: 115VAC/60HZ, 230VAC/60HZ
- Dimensions: PMP-800: 9.3"H x 5.8"W x 5"D (23.6cm x 14.7cm x 12.7cm)
PMP-900: 13.6"H x 8"W x 7.5"D (34.5cm x 20.3cm x 19.1cm)

THEORY OF OPERATION

The PMP Peristaltic Metering Pump can be operated as a stand-alone pump without any circuitry or is available with a limiting timer option.

- Basic models (no circuitry) will run the pump for as long as the power switch is turned on. See the notes in the "Specifications" section above for details on the max run time.
- Time controlled models, detailed below, are available with a KTM-600 limiting timer.

KTM-600 — This pump "Limit Timer" control is designed to control the run time of the pump with the press of a button or input of a signal from a powered switch or remote controller. The water proof control cabinet is normally mounted near the delivery point for the chemical, convenient for operators. Typical delivery points include Gerry cans, buckets, floor scrubbers, portable foamers or other receptacles. For applications where remote triggers such as a CIP or Conductivity control signal are used, the controller can be installed close to the signal source. The signal-input circuit accepts input voltages from 14-240 VAC. The KTM-600 board also has a "Relay Mode" feature that allows the pump to run from a 14 – 240V signal (for as long as the signal is present) or while the push button is held down. Using the relay mode with the push button is well suited for manual feed applications.

INSTALLATION

- (1) Check voltage of installation with a voltmeter and compare with voltage inputs of pump unit before mounting. Application of incorrect voltage will permanently damage unit and is not covered under warranty.
- (2) Mount unit on wall or shelf in a convenient location near both injection point and chemical supply. Do not mount unit in direct path of steam. This can short circuit and permanently damage your system.
- (3) Most systems include a power cord for easy connection. Rigid or flexible conduit can be used to ensure safety and continued operation without shorts. The green ground wire must be applied to ground. Failure to do so will void warranty.
- (4) Install braided tubing between the discharge (right) tube side of the peristaltic pump and the injection point. Use the provided stainless steel hose clamps and barb fittings to secure braided tubing to squeeze tube.
- (5) Install braided tubing between the suction (left) tube side and the barb fitting on the PVC pickup tube provided. Use the provided stainless steel hose clamps and barb fittings to secure braided tubing to squeeze tube.
- (6) Some units are equipped with an optional prime switch which can be used to fill the suction and discharge tubing connected to the pump. Depending on the model, the pump will either run as long as the prime switch is depressed, or will trigger a timed injection set on the control circuit board (if so equipped).

MAINTENANCE

The PMP Series of Metering Pumps require a minimal amount of maintenance to achieve optimal performance. Periodically check the squeeze tube for cracks, deterioration, or swelling. The squeeze tube will typically need to be replaced about every 6 months (chemical compatibility and duty cycle can cause this interval to vary).

Applying lube to the squeeze tube once a month will extend the life of the tube, minimize wear on other contacting parts, and promote smoother pump operation. Use Knight Tube Lube (P/N 7506621) or an equivalent silicone-based lubricant.

- (1) Remove the faceplate of the pump.
- (2) Apply a thin bead of Tube Lube to the inner surface (the side that the rollers contact) of the squeeze tube between the 9 o'clock and 3 o'clock positions. Avoid getting lube near the pinch points where the bottom of the faceplate grips the tube.
- (3) Put the faceplate back on the pump.
- (4) Activate the pump under normal operation — the lubricant will be evenly distributed as the pump rotates.

MODELS WITH KTM-600

Pump Run Time: (max run time is 12 minutes and 42 seconds)

- (1) Locate the dip-switch pack on the circuit board — set switch #6 to SIGNAL, set switch #7 to RUN TIME and set switch #8 to PROGRAM MODE.
- (2) Using a measuring cup or beaker, press Start switch and release when pump starts. Let the pump run until desired amount of chemical is dispensed then press Start switch again to stop. The run time is now programmed. Repeat step if new volume is required.
- (3) Set mode switch #8 to RUN MODE.

Delay Time: (max delay time is 12 minutes and 42 seconds)

- (1) Locate the dip-switch pack on the circuit board — set switch #6 to SIGNAL, set switch #7 to DELAY TIME and set switch #8 to PROGRAM MODE.
- (2) Press Start switch and release when the LED begins flashing. When the desired delay time has passed, press the Start switch again. The delay time is now programmed. Repeat step if new delay time is required.
- (3) Set mode switch #8 to RUN MODE.

Lock-Out Time: (max lock-out time is 31 minutes)

This feature defeats consecutive dispensing of product for a pre-determined interval. Select a combination of switches 1 – 5 to program total lock-out time.

Example: For 10 minute lock-out, set switches #2 and #4 to ON with all other switches OFF.

For maximum lock-out (31 min) set all switches ON.

For no lock-out, set all switches OFF.

OPERATION

Manual activation: Press the Start button for 1 full second. The unit will begin counting down the delay time (if used) and will then run the pump for the amount of time programmed. Once the lock-out time expires (if used) the pump will be ready to restart.

Signal activation: When the signal input on the circuit board receives a 14-240VAC trigger signal for at least 5 seconds, the delay time (if used) will begin counting down. Then the pump will run for the amount of time programmed. Once the lock-out time expires (if used) the pump will be ready to restart.

Relay Mode: Set switch #6 to RELAY. The pump will activate for as long as an external trigger signal is present, or for as long as the manual button is depressed. All other board functions (such as delay time and lock-out time) are by-passed in relay mode.

DISABLING THE START BUTTON

There is a jumper marked “JP1” on the circuit board that can be used to prevent manual activation in certain applications, or to allow manual activation by remote push-button only. This jumper only affects the on-board start button. A remote start button, or trigger signal, can always be used to activate the pump.

- When the jumper is ON, the on-board start button is functional.
- When the jumper OFF, the on-board start button is disabled.

PRIMING

- (1) Locate the dip-switch pack on the circuit board and set switch #6 to RELAY.
- (2) Press and hold the Start button until the chemical line is fully primed, then release the button.
- (3) Set switch #6 to SIGNAL (unless you intend to use relay mode).

KTM-600 CIRCUIT BOARD

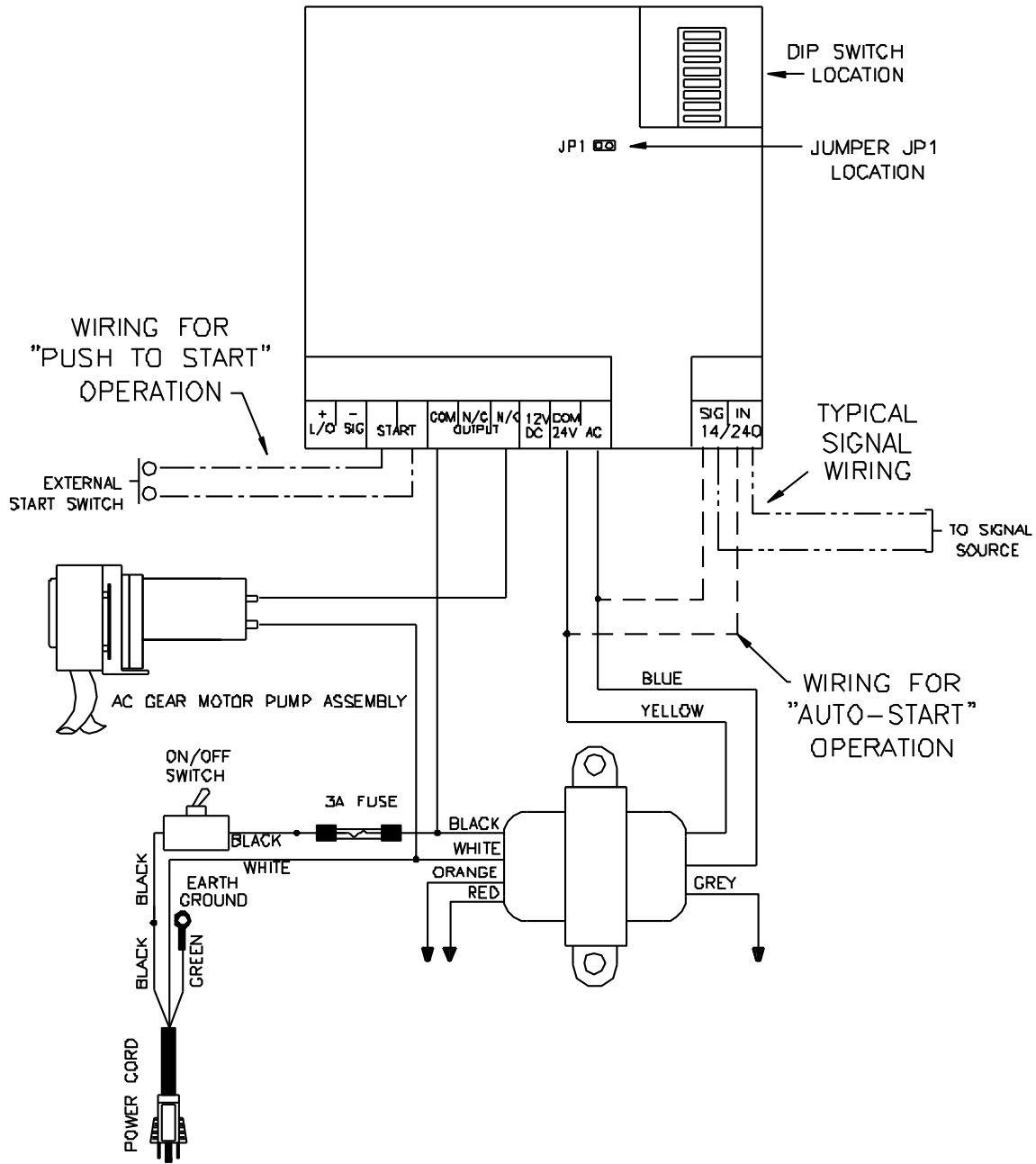

Replacement Part Description No.>>	PMP MODELS					
	PMP-8120B (115 V) Model # 8457830-01	PMP-8120B (230 V) Model # 8457830-02	PMPP-8110V Model # 8457773-01	PMP-9130 Model # 8457760-01	PMP-9270 (No C.B) Model # 8457765-01	PMP-9270 (WITH Control Brd.) Model # 8457765-21
MOTOR	PART # 7010374	PART # 7010372	PART # 7010116 (24 VDC)	PART # 7010230	PART # 7010233	PART # 7010233
BODY	PART # 7631331	PART # 7631331	PART # 7631330	PART # 7630701	PART # 7630701	PART # 7630701
ROLLER	PART # 7633330	PART # 7633330	PART # 7633330		PART # 7630731-1	PART # 7630731-1
FACEPLATE	PART # 7630330	PART # 7630330	PART # 7630330	PART # 7630712	PART # 7630712	PART # 7630712
TUBE "E"	PART # 7018068	PART # 7018068	PART # 7019060	PART # 7028662	PART # 7028662	PART # 7028662
TUBE "D"	N/A	N/A	PART # 7018046	N/A	N/A	N/A
TUBE "M"	PART # 7018011	PART # 7018011	PART # 7018002	PART # 7018016	PART # 7018016	PART # 7018016
TUBE "T"	PART # 7018105	PART # 7018105	PART # 7018102	PART # 7018107	PART # 7018107	PART # 7018107
TUBE "F"	PART # 7018087	PART # 7018087	PART # 7018089		PART # 7018088	PART # 7018088

PUMP VOLUMES	1180 ML / MIN 40 OZ / MIN	1180 ML / MIN 40 OZ / MIN	614 ML / MIN 21 OZ / MIN	4400 ML / MIN 149 OZ / MIN	6600 ML / MIN 223 OZ / MIN	6600 ML / MIN 223 OZ / MIN
--------------	------------------------------	------------------------------	-----------------------------	-------------------------------	-------------------------------	-------------------------------

NOTE: Maximum volumes based on water and "E" Type tubing. Actual volumes will vary depending on product viscosity, pumping distances, and any applicable back pressures.

TYPICAL PUMPHEAD ASSEMBLY

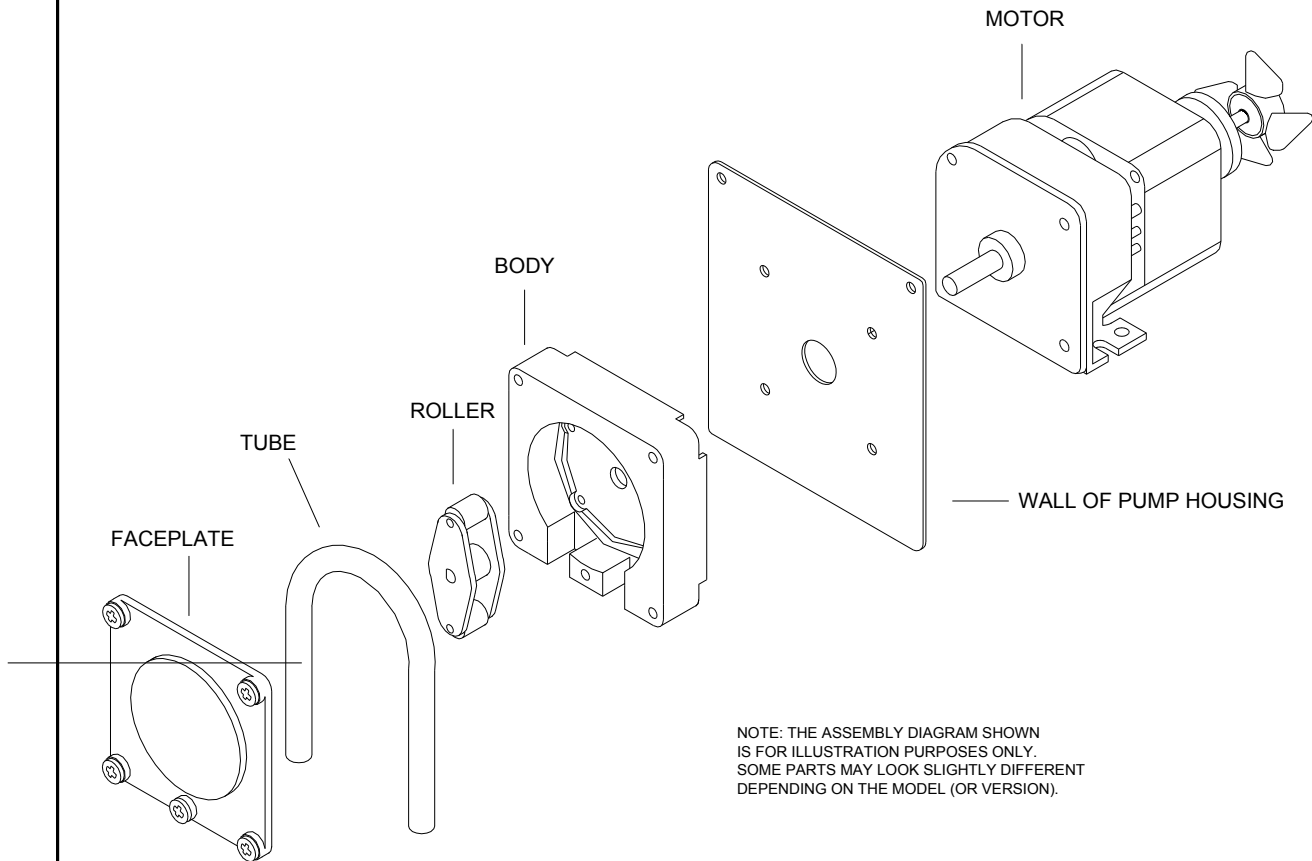

NOTE: THE ASSEMBLY DIAGRAM SHOWN IS FOR ILLUSTRATION PURPOSES ONLY. SOME PARTS MAY LOOK SLIGHTLY DIFFERENT DEPENDING ON THE MODEL (OR VERSION).

PUMPSPECS/072103

DISCLAIMER

Knight LLC does not accept responsibility for the mishandling, misuse, or non-performance of the described items when used for purposes other than those specified in the instructions. For hazardous materials information consult label, MSDS, or Knight LLC. Knight products are not for use in potentially explosive environments. Any use of our equipment in such an environment is at the risk of the user, Knight does not accept any liability in such circumstances.

WARRANTY

For complete product terms and conditions scan the QR code below or enter the following URL into your browser:
<http://cfstech.info/t-and-c>

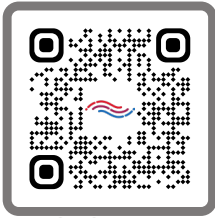

SCAN



KNIGHT LLC is part of the **CFS Technologies** family of brands.

www.knightequip.com | cfstech.com

8504 MacArthur Dr., North Little Rock, AR 72118 USA • 501-895-2820 | 800-999-2820

General: sales@cfstech.com | Tech. Assist.: techsupport@cfstech.com